

10GbE BASE-T Card

User's Manual

COM Express Type 7 10GBASE-T Network Adapter Card



COM 
Express®

Manual Rev.: 1.0
Revision Date: July 7, 2017
Part Number: 50-1J091-1000

Preface

Copyright

Copyright 2017 ADLINK Technology, Inc. This document contains proprietary information protected by copyright. All rights are reserved. No part of this manual may be reproduced by any mechanical, electronic, or other means in any form without prior written permission of the manufacturer.

Disclaimer

The information in this document is subject to change without prior notice in order to improve reliability, design, and function and does not represent a commitment on the part of the manufacturer. In no event will the manufacturer be liable for direct, indirect, special, incidental, or consequential damages arising out of the use or inability to use the product or documentation, even if advised of the possibility of such damages.

Environmental Responsibility

ADLINK is committed to fulfill its social responsibility to global environmental preservation through compliance with the European Union's Restriction of Hazardous Substances (RoHS) directive and Waste Electrical and Electronic Equipment (WEEE) directive. Environmental protection is a top priority for ADLINK. We have enforced measures to ensure that our products, manufacturing processes, components, and raw materials have as little impact on the environment as possible. When products are at their end of life, our customers are encouraged to dispose of them in accordance with the product disposal and/or recovery programs prescribed by their nation or company.

Trademarks

Product names mentioned herein are used for identification purposes only and may be trademarks and/or registered trademarks of their respective companies.

Revision History

Revision	Description	Date	By
1.0	Initial release	2017-07-07	JC

Table of Contents

Preface	ii
List of Figures	iv
List of Tables	v
1. Introduction	1
2. Specifications	3
2.1. Interface.....	3
2.2. 10GbE PHY	3
2.3. Dimensions	3
2.4. Operating Temperatures.....	3
2.5. Specification Compliance	3
2.6. Functional Diagram.....	4
2.7. Mechanical Drawing	5
3. Pinouts and Signal Descriptions	7
3.1. Input Interface Definitions	7
4. Module Interfaces and Configuration	9
4.1. 10GbE BASE-T Card Layout	9
4.2. 10GbE Adapter Card Installation	10
4.3. LED Indicators	11
Getting Service	12

List of Figures

Figure 1: 10GbE BASE-T Card Functional Block Diagram	4
Figure 2: 10GbE BASE-T Card Mechanical Drawing.....	5
Figure 3: 10GbE BASE-T Card Layout	9
Figure 4: 10GbE Adapter Card Installed on Express-BASE7 with Type 7 COM Express Module	10

List of Tables

Table 1: 10GbE BASE-T Card Pin Definitions	7
Table 2: LED Descriptions.....	11

This page intentionally left blank.

1. Introduction

The ADLINK 10GbE BASE-T Card is a 10GbE copper network adapter card that delivers fast 10Gbps network access. It converts up to four 10GBASE-KR interfaces & related sideband signals to four 10GbE copper interfaces (10GBASE-T signals) through 10GbE copper PHY.

The 10GbE BASE-T Card can only be used on products that are PICMG COM Express Type 7 (COM.0 Rev. 3.0) compliant.

By using the 10GbE BASE-T Card with an Express-BASE7 reference carrier board and COM Express Type7 module (with 10GbE controller supporting copper mode), customers can quickly emulate the functionality of their end product for software development and hardware verification. Applications include entry level cloud storage platforms and communications servers.

This page intentionally left blank.

2. Specifications

2.1. Interface

Input	Up to four 10GBASE-KR & related sideband signals from COM Express Type7 module through 164-pin edge connector (PCIe x16 slot PCIEKR on Express-BASE7)
Output	Up to four 10G copper signals (10GBASE-T)

2.2. 10GbE PHY

PHY	Intel® Ethernet Connection X557-AT2 (two 10GbE ports, default BOM configuration) Converts 10GBASE-KR and sideband signals to 10GBASE-T signals Note: Four 10GbE ports optionally supported by project basis with 2nd copper PHY on 10GbE BASE-T card.
EEPROM	Dedicated EEPROM for PHY firmware

2.3. Dimensions

- 168 mm x 107 mm (PCB only, including edge connector)

2.4. Operating Temperatures

Standard Operating Temperature	0°C to +60°C
---------------------------------------	--------------

2.5. Specification Compliance

- PICMG COM.0: Rev 3.0 Type 7

2.6. Functional Diagram

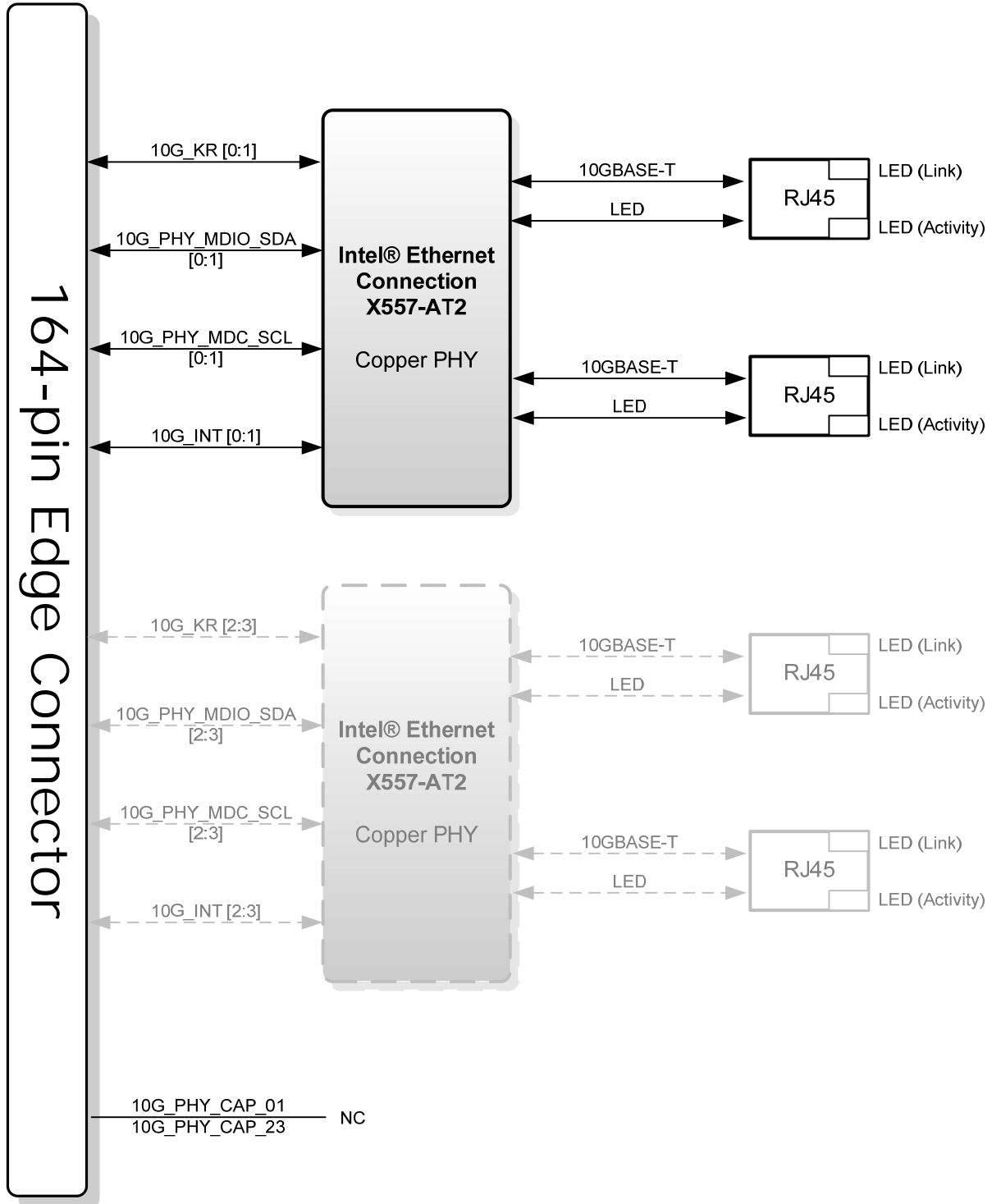
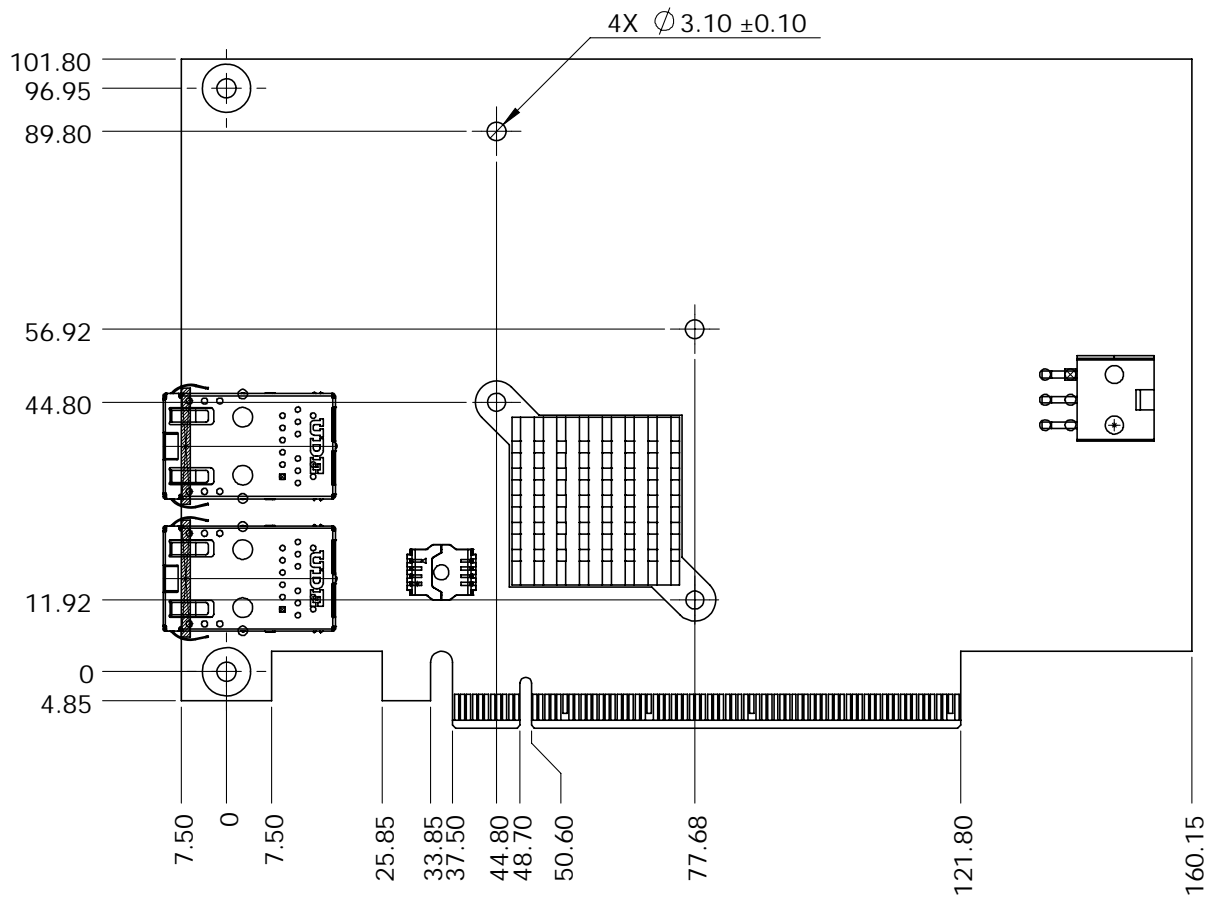

Figure 1: 10GbE BASE-T Card Functional Block Diagram

2.7. Mechanical Drawing



All dimensions are shown in millimeters. Tolerances should be ± 0.25 mm, unless otherwise noted.
The tolerances of the holes (dimensions [0, 0] and [0, 96.95]) should be ± 0.10 mm.

Figure 2: 10GbE BASE-T Card Mechanical Drawing

This page intentionally left blank.

3. Pinouts and Signal Descriptions

3.1. Input Interface Definitions

The 10GbE BASE-T Card is a Type 7 compliant 10GbE adapter card that receives 10GBASE-KR and sideband signals from the COM Express Type7 module and converts them 10GbE copper signals (10GBASE-T).

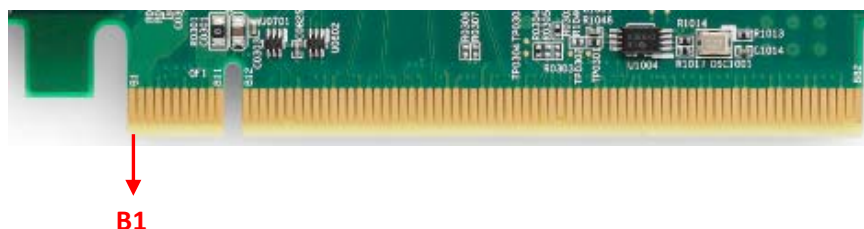

Table 1: 10GbE BASE-T Card Pin Definitions

Row B		Row A	
Pin	Name	Pin	Name
B1	12V	A1	NC
B2	12V	A2	12V
B3	12V	A3	12V
B4	GND	A4	GND
B5	NC	A5	NC
B6	NC	A6	NC
B7	GND	A7	GND
B8	NC	A8	NC
B9	NC	A9	NC
B10	NC	A10	NC
B11	NC	A11	NC
B12	NC	A12	GND
B13	5VSB	A13	NC
B14	5VSB	A14	NC
B15	NC	A15	GND
B16	10G_INT1	A16	10G_INT3
B17	10G_INT0	A17	10G_INT2
B18	GND	A18	GND
B19	10G_PHY_MDIO_SDA3	A19	NC
B20	10G_PHY_MDC_SCL3	A20	GND
B21	GND	A21	10G_PHY_MDIO_SDA2
B22	GND	A22	10G_PHY_MDC_SCL2
B23	10G_KR_RX3+	A23	GND
B24	10G_KR_RX3-	A24	GND
B25	GND	A25	10G_KR_TX3+
B26	GND	A26	10G_KR_TX3-
B27	10G_KR_RX2+	A27	GND
B28	10G_KR_RX2-	A28	GND
B29	GND	A29	10G_KR_TX2+
B30	NC	A30	10G_KR_TX2-
B31	NC	A31	GND
B32	GND	A32	NC
B33	10G_KR_RX1+	A33	NC
B34	10G_KR_RX1-	A34	GND
B35	GND	A35	10G_KR_TX1+

Row B		Row A	
Pin	Name	Pin	Name
B36	GNF	A36	10G_KR_TX1-
B37	10G_PHY_MDIO_SDA1	A37	GND
B38	10G_PHY_MDC_SCL1	A38	GND
B39	GND	A39	10G_PHY_MDIC_SDA0
B40	GND	A40	10G_PHY_MDC_SCL0
B41	10G_KR_RX0+	A41	GND
B42	10G_KR_RX0-	A42	GND
B43	GND	A43	10G_KR_TX0+
B44	GND	A44	10G_KR_TX0-
B45	NC	A45	GND
B46	NC	A46	GND
B47	GND	A47	10G_PHY_CAP_23
B48	NC	A48	10G_PHY_CAP_01
B49	GND	A49	GND
B50	NC	A50	NC
B51	NC	A51	GND
B52	GND	A52	NC
B53	GND	A53	NC
B54	NC	A54	GND
B55	NC	A55	GND
B56	GND	A56	NC
B57	GND	A57	NC
B58	NC	A58	GND
B59	NC	A59	GND
B60	GND	A60	NC
B61	GND	A61	NC
B62	NC	A62	GND
B63	NC	A63	GND
B64	GND	A64	NC
B65	GND	A65	NC
B66	NC	A66	GND
B67	NC	A67	GND
B68	GND	A68	NC
B69	GND	A69	NC
B70	NC	A70	GND
B71	NC	A71	GND
B72	GND	A72	NC
B73	GND	A73	NC
B74	NC	A74	GND
B75	NC	A75	GND
B76	GND	A76	NC
B77	GND	A77	NC
B78	NC	A78	GND
B79	NC	A79	GND
B80	GND	A80	NC
B81	NC	A81	NC
B82	NC	A82	GND

Note: Four 10GbE ports are supported by project basis.

4. Module Interfaces and Configuration

This chapter describes connectors and pinouts, LEDs and switches that are used on the 10GbE adapter card.

4.1. 10GbE BASE-T Card Layout

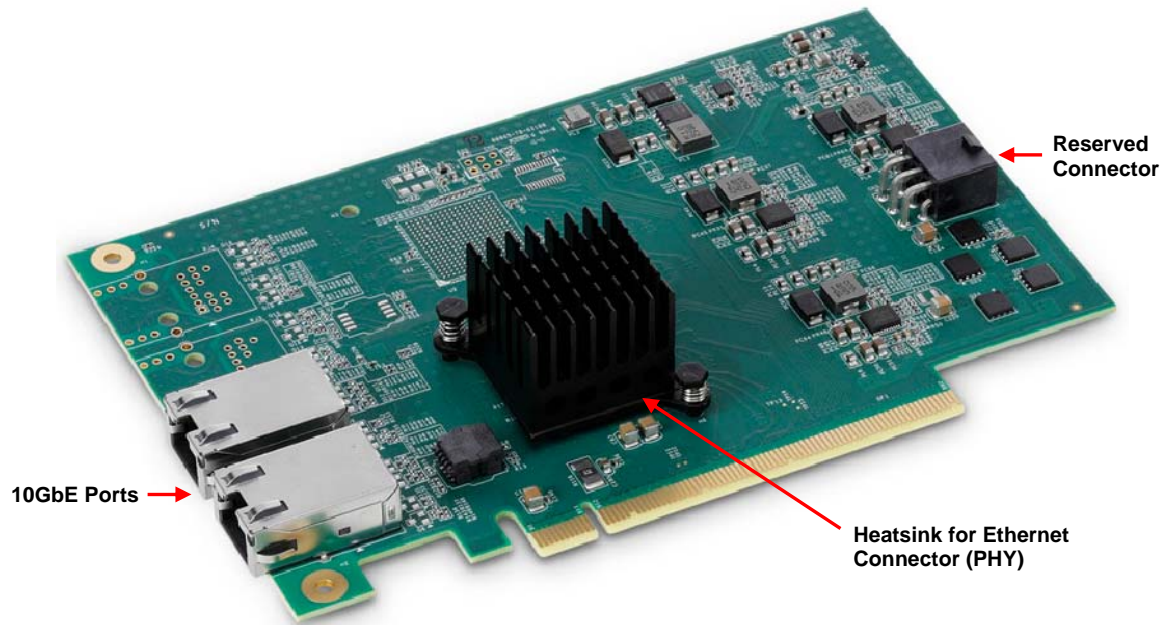

Figure 3: 10GbE BASE-T Card Layout

Note: See 4.3 LED Indicators for detailed 10GbE port status LED information.

4.2. 10GbE Adapter Card Installation

Below is an example of a 10GbE adapter card installed on the Express-BASE7 carrier board with a Type 7 COM Express Module (or illustration purposes only).

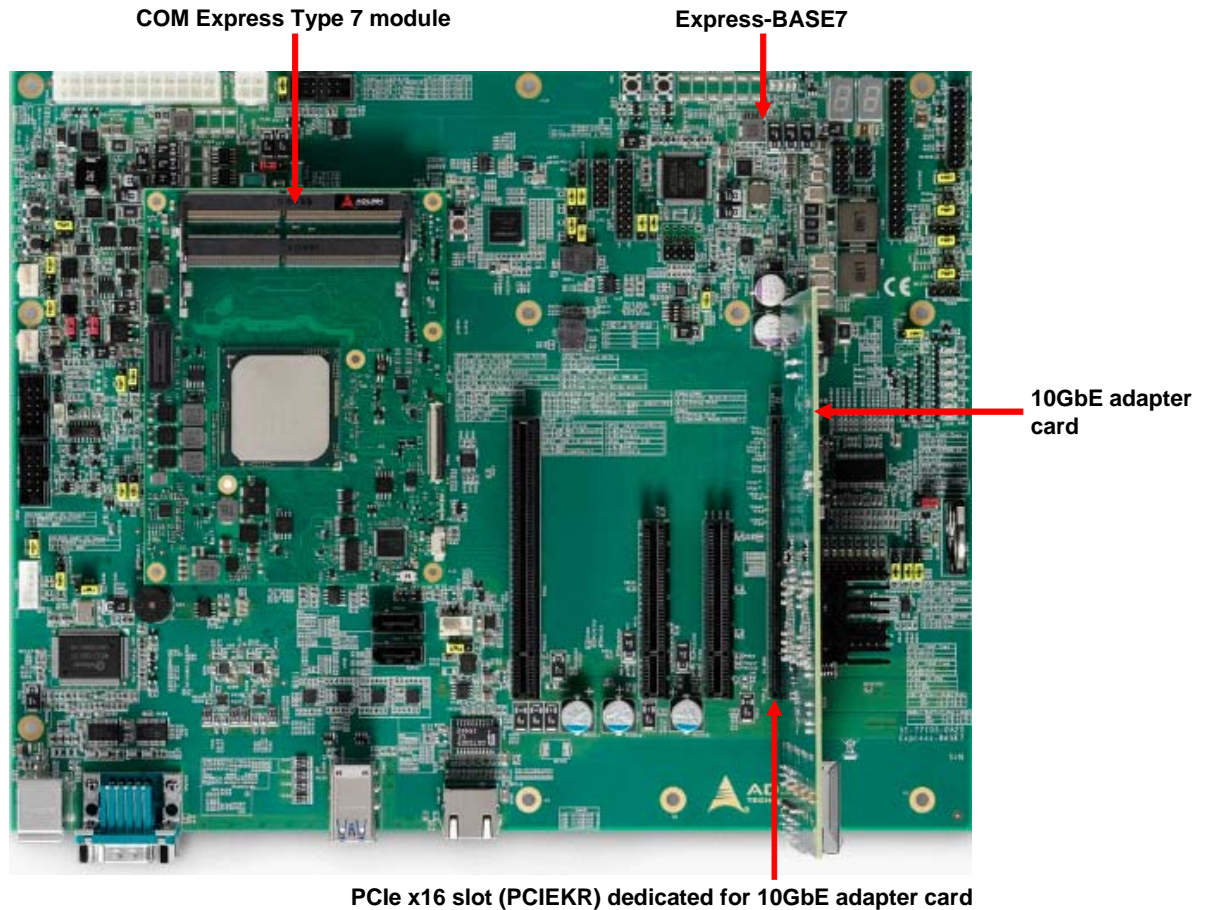
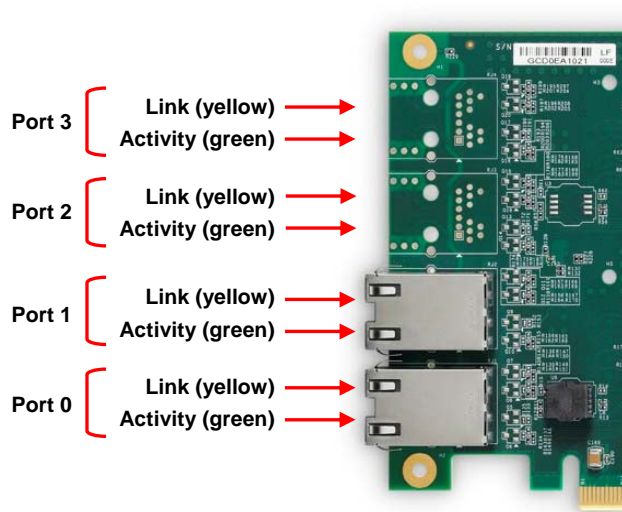

Figure 4: 10GbE Adapter Card Installed on Express-BASE7 with Type 7 COM Express Module

4.3. LED Indicators

There are two status LEDs for each 10GBASE-T port (link and activity).



Name	Color	Indication
Link	Yellow	On when linked
Activity	Green	Blinking when active

Table 2: LED Descriptions